

95 MTS

Multi Tank Systems Water Softeners & Filters

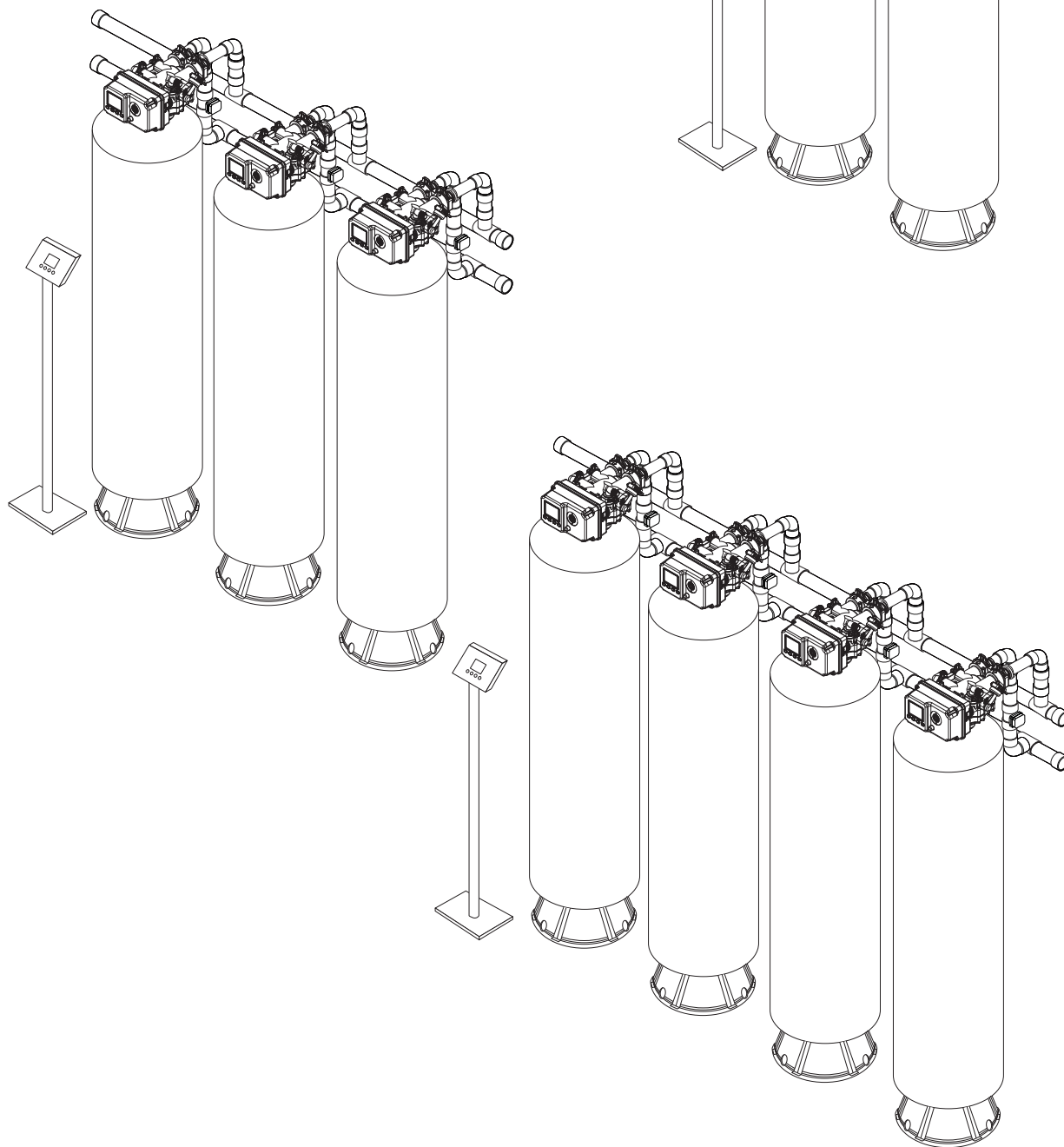

Canature WaterGroup Canada Inc.
855 Park St., Unit 1
Regina, SK, S4N 6M1
Toll Free: (877) 288-9888

Canature WaterGroup U.S.A. Inc.
6353 Commerce Drive
Whitestown, IN, 46075
Toll Free: (877) 288-9888

Table of Contents

INTRODUCTION	4
SYSTEM CONFIGURATION	4
INSTALLATION INSTRUCTIONS	5
START-UP INSTRUCTIONS	5
SYSTEM DIAGRAM	6
PROGRAMMING	7
ADVANCED PROGRAMMING	17
MTS WIRING SCHEMATICS	20
REMOVING POWER HEAD ASSEMBLY	24
REPLACE DRAIN LINE FLOW CONTROL (DLFC)	25
REPLACE BRINE LINE FLOW CONTROL (BLFC)	25
REPLACING OR CLEANING INJECTORS	26
MTS SYSTEM COMPONENTS	27
POWER HEAD EXPLODED VIEW	28
POWER HEAD PARTS NUMBERS	29
VALVE BODY EXPLODED VIEW	30
VALVE BODY PARTS NUMBERS	31
TROUBLE SHOOTING	33
MAINTENANCE LOGS	34
WARRANTY	40

INTRODUCTION

STANDARD FEATURES

MTS systems have been designed and engineered to offer considerable performance advantages compared to traditional products in the Commercial & Light Industrial market today.

HIGH EFFICIENCY & HIGH QUALITY PRODUCT WATER

MTS systems are optimized to use the minimum salt and regeneration water necessary to regenerate the system. This reduces water and salt wasted per regeneration up to 50%.

When used in softener & filter systems during periods of low flow rates, the controller will keep only a single tank in service eliminating the potential for "channeling". Tanks are brought on or off line according to flow rate demand so that the system is always operating at peak efficiency.

OPTIONS

POLISHING RECYCLE RINSE - For softener systems an option for Polishing Recycle Rinse is available. Prior to a tank coming on line

product water is recycled through the tank to polish the water and insure no hardness is passed to the service line. If the flow rate drops below the point where channeling can occur, the system will also recycle product water to maintain high quality.

BATTERY BACK UP - A battery back up system allows the controller to continue metering and tracking water usage for up to 9 hours so that all capacity used during the outage is accounted for.

REMOTE START - An external remote button can easily be added so that the system can be manually started from a control room or other location.

ADVANCED DIAGNOSTICS - The system has advanced diagnostics to help troubleshoot any problems that may be encountered.

REMOTE MONITORING (NOT AVAILABLE AT THIS TIME) - The MTS system can easily connect to a PC directly or wirelessly (3G network) to the internet and to your PC. All system information and settings can be viewed and monitored.

SYSTEM CONFIGURATION

MTS95 Softener System Configuration			
Tank Size (Diameter)	Injector Set	Brine Line Flow Control (BLFC)	Drain Line Flow Control (DLFC)
14"	#4S Black	0.9 GPM	#4S (5.0 GPM)
16"	#5S Orange/Black Noz		#7S (7.0 GPM)
18"	#1 Gray	1.35 GPM	#1 (8.0 GPM)
21"	#3 Red		#2 (11.0 GPM)
24"	#4White		#4 (17.0 GPM)

Suggested Filter Valve Configuration	
Tank Size (Diameter)	Drain Line Flow Control (DLFC)
14"	#3 (14.0 GPM)
16"	#4 (17.0 GPM)
18"	#5 (21.0 GPM)
21"	#6 (24.0 GPM)
24"	None (35.0 GPM)

INSTALLATION INSTRUCTIONS

1. Locate the system close to a drain where the system will be installed. The surface should be clean and level.
2. Connect the inlet and outlet of the softener using appropriate fittings. Perform all plumbing according to local plumbing codes. Any solder joints near the valve or any other plastic connections must be done before connecting any piping. Always leave at least 6" (152 mm) between the joints when soldering pipes that are connected. Failure to do this could cause damage.
3. Connect 3/4" drain hose to each valve and secure it with a hose clamp. Run the drain hose to the nearest drain pipe. This can be ran up overhead or down along the floor. If running the drain line more than 20 ft overhead, it is recommended to increase the hose size to 1".

NEVER MAKE A DIRECT CONNECTION INTO A WASTE DRAIN. A PHYSICAL AIR GAP OF AT LEAST 1.5" SHOULD BE USED TO AVOID BACTERIA AND WASTEWATER TRAVELLING BACK THROUGH THE DRAIN LINE INTO THE SYSTEM.

4. Connect the brine tanks to each valve.
5. Close the isolation ball valves to each control valve. Open the main bypass ball valve to the open position. Slowly turn on the main water supply. At the nearest cold treated water tap nearby open and let water run a few minutes or until the system is free of any air or foreign material resulting from the plumbing work.
6. Make sure there are no leaks in the plumbing system before proceeding. Close the water tap when water runs clean.
7. Open the brine tank salt lid and add water until there is approximately 3" (75 mm) of water in the tank. Do not add salt to the brine tank at this time
8. Proceed to start up instructions.

NOTE: The unit is not ready for service until you complete the start-up instructions.

START-UP INSTRUCTIONS

KEY PAD CONFIGURATION

- MENU** - Enter or exit the system menu. Press and hold the button for 3 seconds to unlock the screen.
- SET/REGEN** - Press this button to select a program or to save the settings. Press and hold the button for 3 seconds to initiate a manual regeneration.
- DOWN / UP** - Press these buttons to increase or decrease the value of the settings. Press the buttons to enter the previous or the next menu.

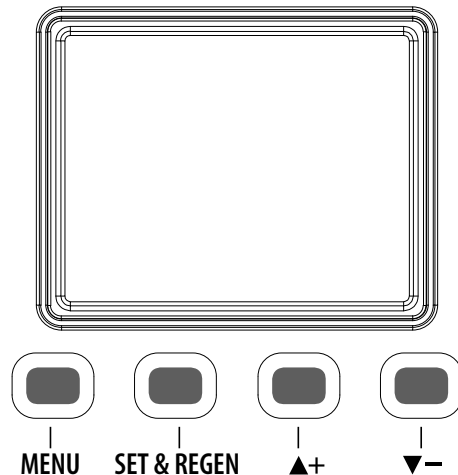

START-UP INSTRUCTIONS (CONTINUED)

1. Plug the valve and main controller into an approved power source.
2. Connect data(4 pin) and power(2 pin) cables between multiple valves via daisy chain from the main controller. Also ensure all meter cables are plugged in.
3. Step each valve into the BACKWASH position. For the MTS valve, this must be done on the MAIN controller. Use the UP or Down key to highlight each tank in the system. Press and hold the SET / REGEN button for 3 seconds to start a manual regeneration for that tank.
4. Open the outlet isolation valve on each tank slowly and allow water to enter the unit. Allow all air to escape from the unit before turning the water on fully then allow water to run to drain for 3-4 minutes or until all media fines are washed out of the tank indicated by clear water in the drain hose.
5. For softener systems, press any button on each valve to advance to the BRINE position. Check the water level in the brine tank to ensure the valve is drawing brine properly.
6. Press any button on each valve to advance to the RINSE position. Check the drain line flow. Allow the water to run for 3-4 minutes or until the water is clear.
7. For softener systems, press any button on each valve to advance to the REFILL position. Check that the valve is filling water into the brine tank. Allow the valve to refill for the full amount of time as displayed on the screen to insure a proper brine solution for the next regeneration.
8. The valve will automatically advance to the SERVICE position when the refill cycle is complete.
9. Open the inlet and outlet isolation valves. Close the main bypass valve.
10. Add salt into the brine tanks.
11. Program the system.

SYSTEM DIAGRAM

MAIN PAGE DISPLAY

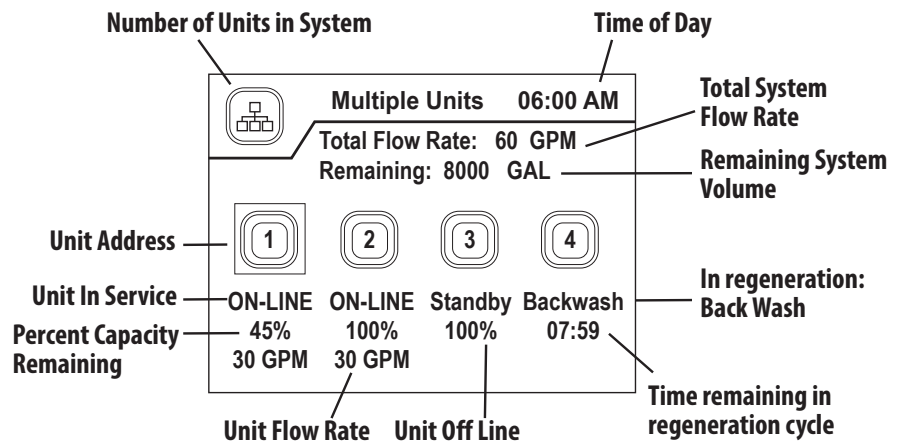

MAIN SYSTEM COMPONENTS

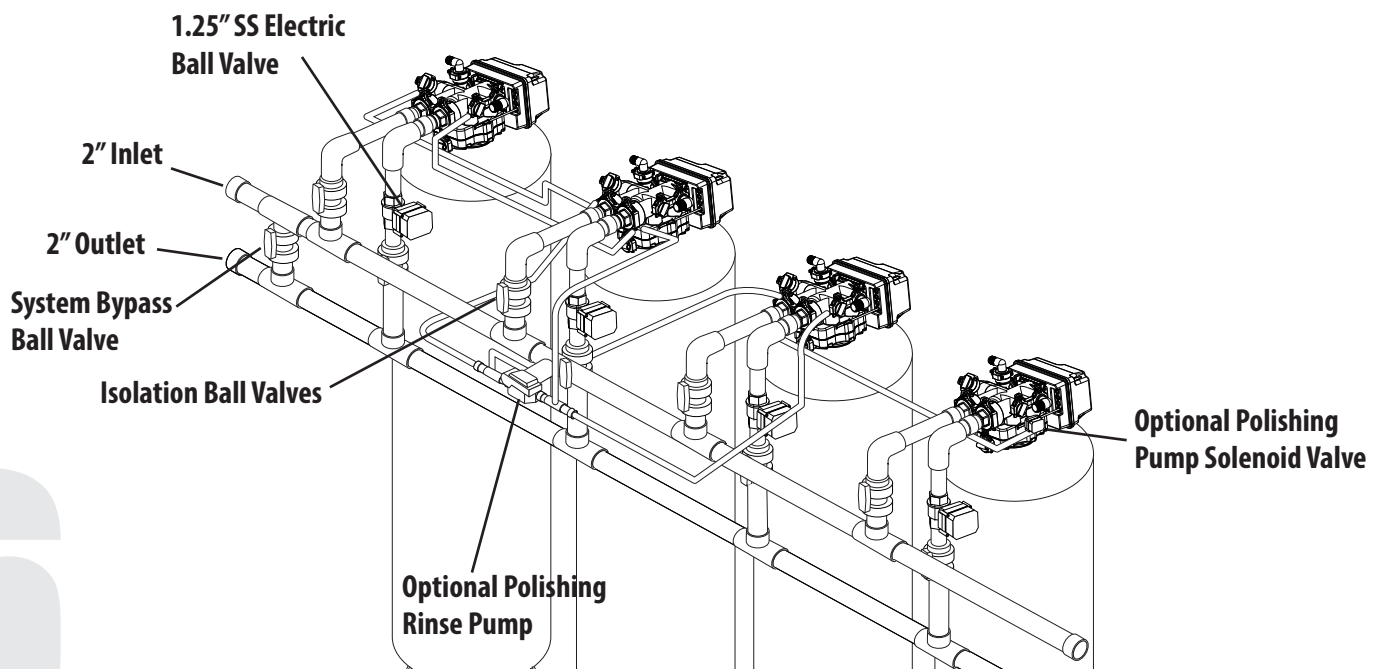

PROGRAMMING

Press the MENU button to advance to the first menu page.

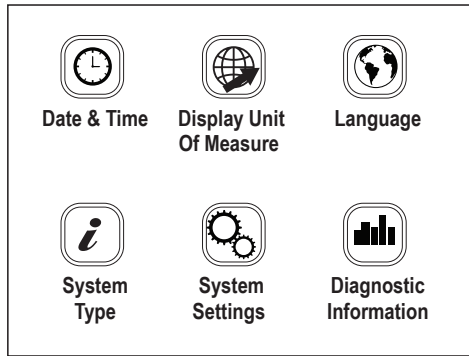

Press the UP / DOWN button to highlight and choose the menu. Press the SET button to enter the menu icon you want to edit. The displayed value will begin flashing. Press the UP / DOWN button to adjust the value. Press the SET button again to accept the change.

DATE AND TIME, REGION, LANGUAGE

The first three menus are standard for all systems. Press the UP / DOWN button to choose the Date and Time, Region, or Language menus. Some software versions may only include US Gallons and English language options. The options inside the System Settings Menu will vary depending on the System Type chosen. The Diagnostic Information will also vary depending on the System Type chosen.

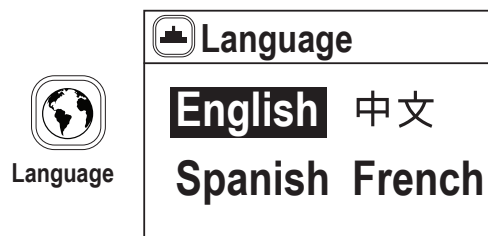
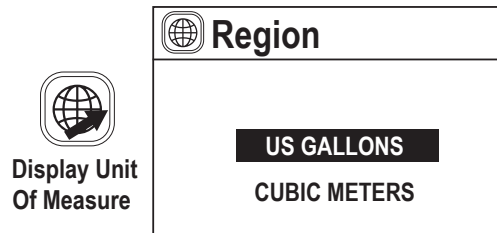
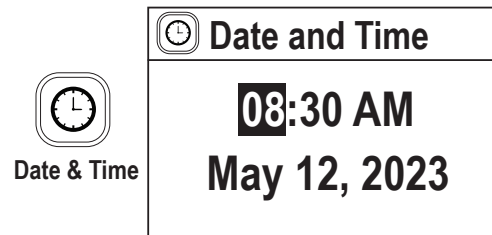

PROGRAMMING (CONTINUED)

SYSTEM TYPE

This menu controls the type of systems available with MTS. All MTS systems can operate with 2 to 16 valves.

SOFTENER (DEMAND FLOW)

As flow rate demand increases and passed the preset trip points, external motorized ball valves on each control valve are opened to bring additional tanks on-line to increase flow capacity. When the demand goes down below the trip points, the tanks are taken off-line. When the capacity of a tank is depleted, it will immediately go into regeneration. The outlet valve will close to prevent any hard water from entering the service line. Only one tank may regenerate at a time.

If the system forecasts a future period of high demand and the current capacity is not enough, the system will automatically regenerate the tank with the least capacity remaining to restore enough capacity to cover the high period of demand.

FILTER (TIME CLOCK)

At the preset regeneration time, a regeneration will occur. The regeneration can be scheduled on certain days of the week or by set intervals of days between. The outlet valve will close to prevent any raw water from entering the service line. Only one tank may regenerate at a time. The tanks will regenerate in sequence one by one.

FILTER (METER DELAY)

When the preset total system capacity reaches zero, a regeneration will be scheduled at the next preset regeneration time. The outlet valve will close to prevent any raw water from entering the service line. Only one tank may regenerate at a time. The tanks will regenerate in sequence one by one.

FILTER (METER IMMEDIATE)

When the preset total system capacity reaches zero, a regeneration will occur immediately. The outlet valve will close to prevent any hard water from entering the service line. Only one tank may regenerate at a time. The tanks will regenerate in sequence one by one.

FILTER (PRESSURE DROP)

When the pressure drop across an individual filter reaches the trip point, a regeneration will occur immediately. The outlet valve will close to prevent any hard water from entering the service line. Only one tank may regenerate at a time. The tanks will regenerate only when they have reached the pressure drop trip point.

Press the SET button to enter the System Type menu icon. A password is required to unlock this screen to prevent non-qualified persons from making changes. The password is 1, 2, 3, 4

8

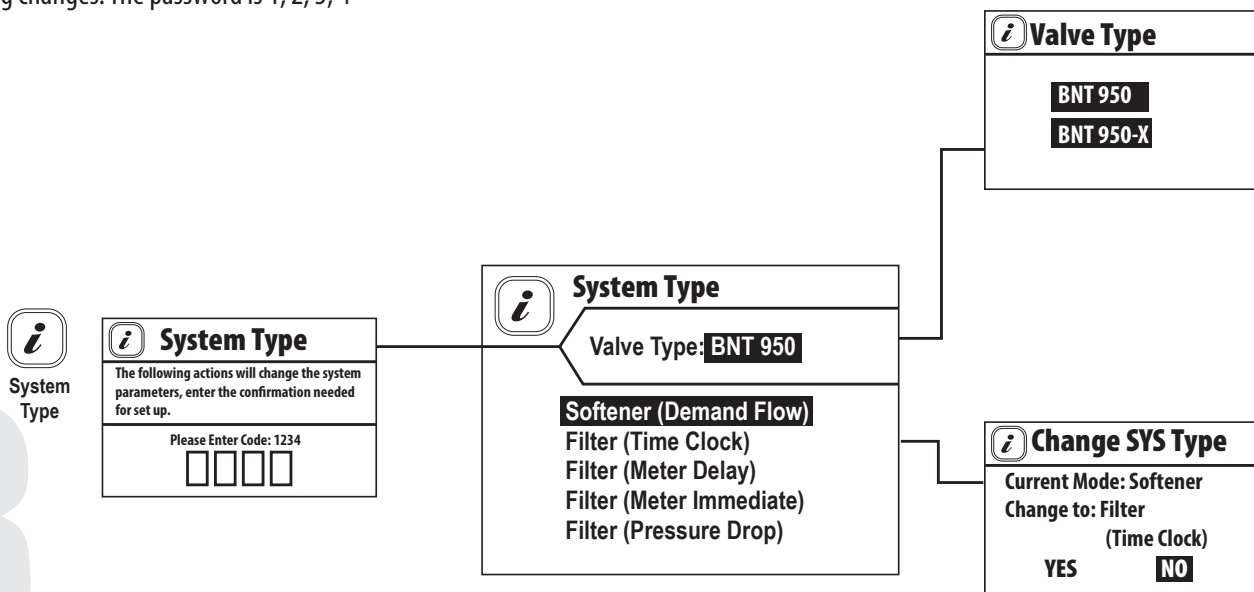

PROGRAMMING (CONTINUED)

For standard MTS system the default Valve Type is BNT 950. When changing from different modes, a page will displayed that will confirm you want to change the System Type. Select Yes to change the type and No to keep the current settings. A System Setting page will be displayed. These options are covered in the Advanced Programming section and are only needed when you are replacing a valve / controller in the system at a later time. Press the MENU button to exit the System Setting page and return to the Main Menu.





If you are changing a Main PCB or or valve PCB it may be necessary to format them. Format Valve, Restore History Data, and Restore Settings are covered in the Advanced Programming Section.

SYSTEM TYPE - (SOFTENER)

Press the UP / DOWN button to highlight the System Settings menu icon. Press the SET button to enter the menu.



System Settings

 System Size	 Salt Efficiency	 Feed Water
 Regeneration Cycle Times	 Advanced Settings	

Press the UP / DOWN button to highlight the desired menu icon. Press the SET button to enter the System Size menu. In the System Size menu you can edit the number of units, amount of softener resin per unit, and the refill flow rate (DLFC).



System Size

 System Size	
Total Units	6
Resin Per Unit	10.00 CF
Resin Flow Rate	0.5 GPM

Press the UP / DOWN button to highlight the desired menu icon. Press the SET button to enter the Salt Efficiency menu In the System Size menu you can choose High Efficiency (6lbs per CF), Standard Efficiency (10lbs per CF), or High Capacity salt settings (15lbs/CF). The system capacity is automatically calculated based on the System Size and Salt Efficiency.



Salt Efficiency

 Salt Efficiency
<input type="checkbox"/> High Efficiency
<input type="checkbox"/> Standard Efficiency
<input type="checkbox"/> High Capacity

PROGRAMMING (CONTINUED)

Press the UP / DOWN button to highlight the desired menu con. Press the SET button to enter the Feed Water menu. In the Feed Water menu you can enter the Hardness, Iron and Manganese concentrations.



Feed Water

Feed Water

Hardness	20 GPG
Iron	0.0 PPM
Manganese	0.0 PPM

Press the UP / DOWN button to highlight the desired menu icon. Press the SET button to enter the Regen. Cycle menu. The default values are already preset for optimized operation based on the system settings. In the Regen. Cycle menu you can edit the Backwash, Brine and Rinse settings. Refill time is automatically calculated. The Backwash Override setting can be adjusted here as well. This setting controls the number of Backwash cycles to be skipped.



Regeneration Cycle Times

Regen. Cycle

Backwash	15 Min
Brine	50 Min
Rinse	10 Min
Refill	Min
Backwash Override	10 Min

Tank Size, Inch	Model	CF Resin	15lb			10lb			6lb		
			BW Time, (min)	Brine Time, (min)	Rinse Time, (min)	BW Time, (min)	Brine Time, (min)	Rinse Time, (min)	BW Time, (min)	Brine Time, (min)	Rinse Time, (min)
14x65	90	3	9	68	9	9	53	9	9	46	9
16x65	120	4	9	69	9	9	54	9	9	47	9
18x65	150	5	9	66	9	9	52	9	9	45	9
21x62	180	6	8	65	8	8	51	8	8	44	8
21x62	210	7	10	60	10	10	47	10	10	41	10
24x72	240	8	7	77	7	7	60	7	7	52	7
24x72	300	10	9	69	9	9	54	9	9	47	9

Press the UP / DOWN button to highlight the desired menu icon. Press the SET button to enter the Advanced Settings. Advanced settings are factory pre-set and should only be changed by qualified technicians.



Advanced Settings

Trip Point Settings

Peak Period Block Out

Auxillary Outputs

Salt Efficiency Settings

Chemical Pump

Product Water Polish

PROGRAMMING (CONTINUED)

Press the UP / DOWN button to highlight the desired menu icon. Press the SET button to enter the Trip Point Settings. These settings determine what flow rate will cause additional tanks to come on line to increase flow capacity.

TRIP DELAY TIME ON

This value controls the delay time in seconds that the flow rate must exceed the Trip Flow Rate before the next tank will come on line.

TRIP FLOW RATE ON

This value controls the flow rate that must be exceeded before the next tank will come on line.

TRIP FLOW RATE OFF

This value controls the flow rate limit that the actual flow must be less than before the tank will come off-line. The default delay time is 5 minutes and is not adjustable.

TRIP DELAY TIME OFF MULTIPLE

This value controls the factor of time (Trip Delay Time Sec x Multiple) for the Trip Flow Rate Off delay. i.e. Trip Delay On Time = 30 sec, Multiple = 10, therefore Trip Delay Off Time = 600 sec



Trip Point Settings			
	Trip Delay (SEC)	Trip Flow Rate (GPM)	
		ON	OFF
Unit 1st	30	15	10
Unit 2nd	30	30	20
Unit 3rd	30	45	30
Unit 4th	30	60	40
Unit 5th	30	75	50

Trip Point Settings			
	Trip Delay (SEC)	Trip Flow Rate (GPM)	
		ON	OFF
Multiple	10		

Press the UP / DOWN button to highlight the desired menu icon. Press the SET button to enter the Peak Period Block Out settings. These settings allow the user to block out two periods per day where a regeneration will not be allowed. At the end of a Peak Period, and units scheduled for regeneration will start.

NOTE: It is not recommended to use this function with softener mode.



Peak Period Block Out				
	Start 1	End 1	Start 2	End 2
MON.	06:00	09:00	17:00	19:00
TUES.	06:00	09:00	17:00	19:00
WED.	06:00	09:00	17:00	19:00
THURS.	06:00	09:00	17:00	19:00
FRI.	06:00	09:00	17:00	19:00
SAT.	06:00	09:00	17:00	19:00
SUN.	06:00	09:00	17:00	19:00

PROGRAMMING (CONTINUED)

Press the UP / DOWN button to highlight the desired menu icon. Press the SET button to enter the Auxiliary Outputs menu. For detailed programming instructions please see the Advanced Programming section.



Auxillary Outputs

Auxillary Outputs	
Remote Start Switch 1	Immediately
Remote Start Switch 1	Hold
AUX Relay 1	Duration Regeneration
AUX Relay 2	Water Polish

Press the UP / DOWN button to highlight the desired menu icon. Press the SET button to enter the Salt Efficiency Settings Menu. A password is required to un-lock this screen to prevent non-qualified persons from making changes. The password is 1, 2, 3, 4. These settings are Factory Set.

Minimum Residual setting controls at what minimum system reserve capacity percentage a regeneration will be scheduled to increase capacity of the entire system. This setting is Factory Set.

Minimum Residual / Unit setting controls at what minimum reserve capacity percentage each individual tank a regeneration will be scheduled. It is factory set at 3% to allow for variation in capacity due to flow rates and fluctuating hardness.



Salt Efficiency Settings

Salt Efficiency
The following actions will change the system parameters, enter the confirmation needed for set up.
Please Enter Password: □ □ □ □

Salt Efficiency Settings			
High Efficiency	6 Lbs/CF	3650 Grains	
Standard Efficiency	10 Lbs/CF	2800 Grains	
High Capacity	15 Lbs/CF	2000 Grains	
Minimum Residual	15 %	Minimum Residual/UNIT	3 %

PROGRAMMING (CONTINUED)

Press the UP / DOWN button to highlight the desired menu icon. Press the SET button to enter the Chemical Pump menu. This setting will control the Time On (Seconds) per Volume (Gallon) of water passed through the system.



Chemical Pump

 Chemical Pump	
CON BY AUX RELAY 1	
Volume	100 GAL
Time On	10 SEC

Press the UP / DOWN button to highlight the desired menu icon. Press the SET button to enter the Product Water Polish menu. The Min Flow Rate setting will control at what flow rate the Product Water Recycle Pump will turn on to recycle the water and avoid hardness channelling through the bed.

The Time On function controls how long the Product Water Recycle Pump will turn on each time the tank comes into service. This will polish the water and avoid any hardness to leak into the service line.



Product Water Polish

 Product Water Polish	
CON BY AUX RELAY 2	
Min Flow Rate	5 GPM
Time On	20 Sec

NOTE: For the Chemical Pump function or Product Water Polish function, the options must be selected the Auxiliary Out Put Menu. Please refer to the Advance Programming section.



Auxillary Outputs

Remote Start Switch 1	OFF
Remote Start Switch 1	OFF
AUX Relay 1	Chemical Pump
AUX Relay 2	Water Polish

PROGRAMMING (CONTINUED)

SYSTEM TYPE - FILTERS

Press the SET button to enter the System Type menu icon. A password is required to unlock this screen to prevent non-qualified persons from making changes. The password is 1, 2, 3, 4.

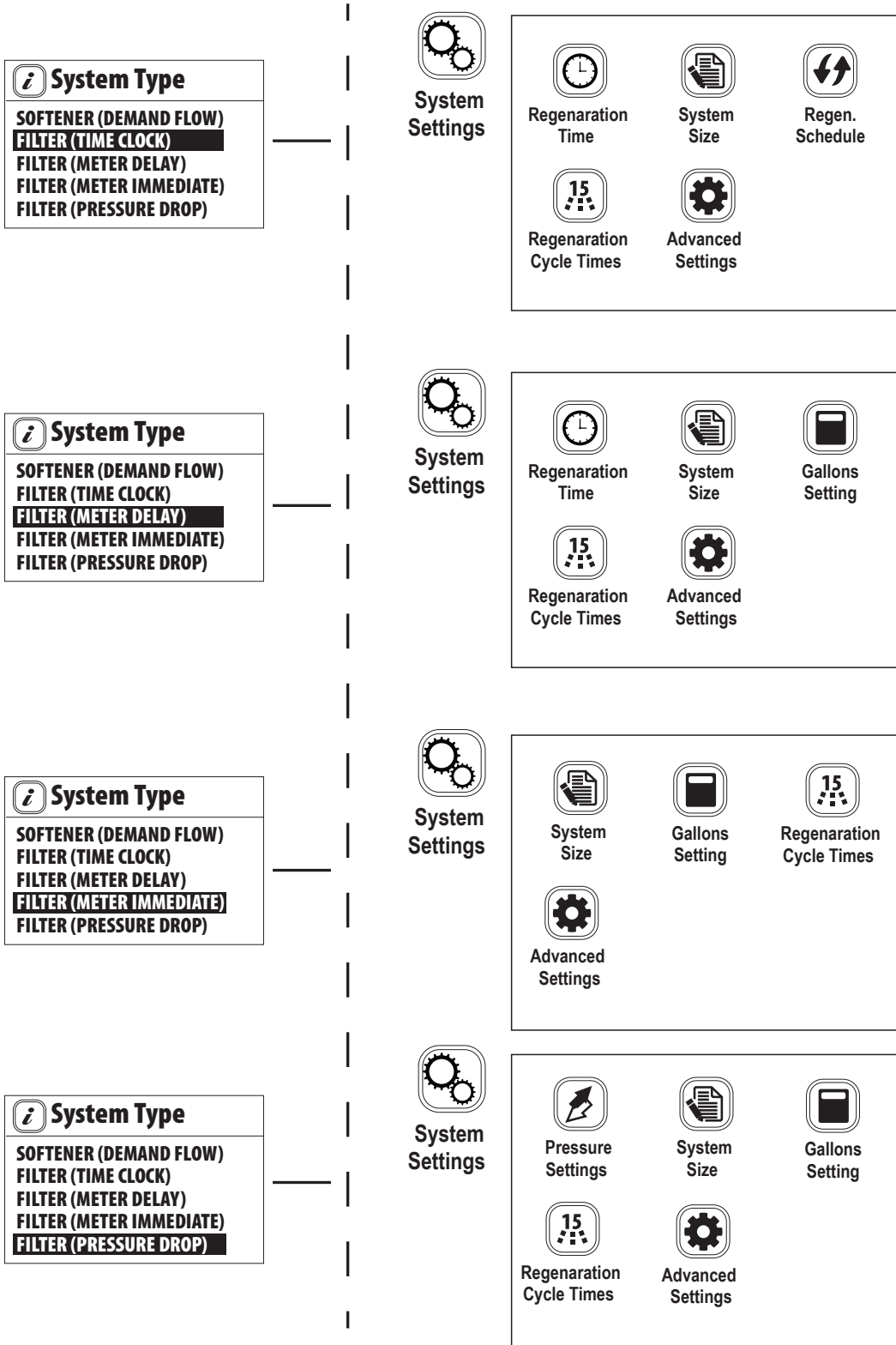

PROGRAMMING (CONTINUED)

Press the UP / DOWN button to highlight the desired menu icon. Press the SET button to enter the Regen. Time menu. In the Regen. Time menu you can edit the time of day a regeneration will occur.

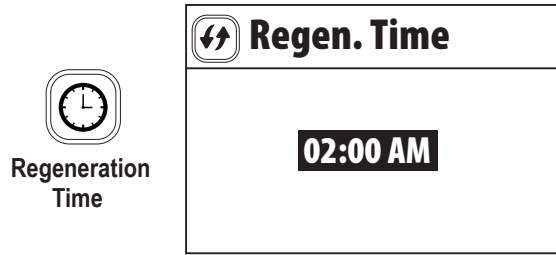

Press the UP / DOWN button to highlight the desired menu icon. Press the SET button to enter the System Size menu. In the System Size menu you can adjust the number of tanks / valves in the system.

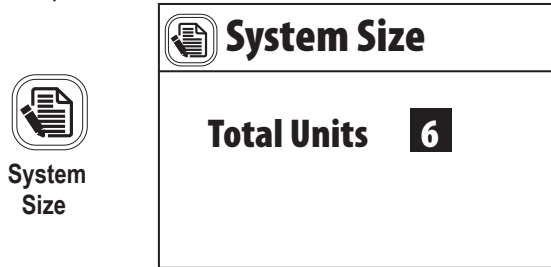

Press the UP / DOWN button to highlight the desired menu icon. Press the SET button to enter the Regen. Schedule menu. In the Regen. Schedule menu you can set the system to regenerate by Number of Days or choose specific days of the week.

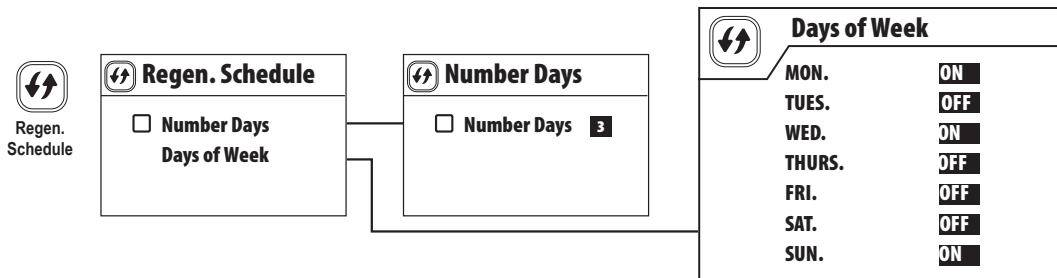

Press the UP / DOWN button to highlight the desired menu icon. Press the SET button to enter the Gallons Setting menu. In the Gallons Setting menu, you can adjust the gallon capacity of the system. In Filter (Pressure Drop) mode, you can adjust the trip point pressure and trip time delay to initiate a regeneration.

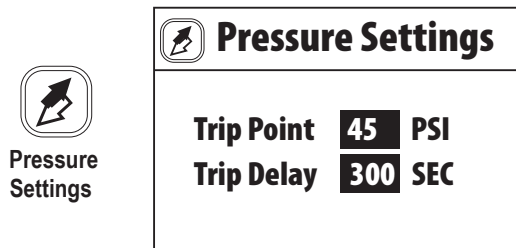
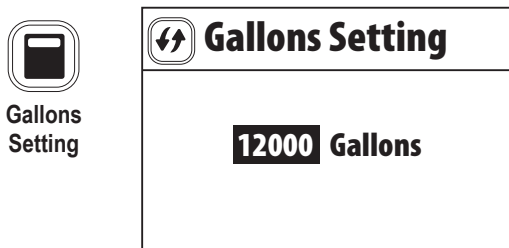

PROGRAMMING (CONTINUED)

Press the UP / DOWN button to highlight the desired menu icon. Press the SET button to enter the Regen. Cycle menu. In the Regen. Cycle menu you can set the system Backwash and Rinse times. The times apply to all the tanks in the system.



Regeneration
Cycle Times



Regen. Cycle

Backwash **10Min**

Rinse **10Min**

Press the UP / DOWN button to highlight the desired menu icon. Press the SET button to enter the Advanced Settings menu.



Advanced
Settings



Peak Period
Block Out



Auxillary
Outputs



Chemical
Pump

Press the UP / DOWN button to highlight the desired menu icon. Press the SET button to enter the Peak Period Block Out settings. These settings allow the user to block out two periods per day where a regeneration will not be allowed. At the end of a Peak Period, and units scheduled for regeneration will start.

NOTE:
SET THE TIMES SO
THAT THEY ARE
ALL EQUAL VALUE
IF NO BLOCK OUT
PERIODS ARE DESIRED.

Press the UP / DOWN button to highlight the desired menu icon. Press the SET button to enter the Auxiliary Outputs or Chemical Pump menu. For detailed programming instructions please see the Advanced Programming section.



Peak Period
Block Out



Peak Period Block Out

	Start 1	End 1	Start 2	End 2
MON.	06:00	09:00	17:00	19:00
TUES.	06:00	09:00	17:00	19:00
WED.	06:00	09:00	17:00	19:00
THURS.	06:00	09:00	17:00	19:00
FRI.	06:00	09:00	17:00	19:00
SAT.	06:00	09:00	17:00	19:00
SUN.	06:00	09:00	17:00	19:00

ADVANCED PROGRAMMING

AUXILIARY OUTPUTS

From the Advanced Settings menu, press the UP / DOWN button to highlight the Auxiliary Output menu icon. Press the SET button to enter.



Auxiliary Outputs	
Remote Start Switch 1	Immediately
Remote Start Switch 1	Hold
AUX Relay 1	Duration Regeneration
AUX Relay 2	Chemical Pump

REMOTE START SWITCH 1 AND 2

There are 2 inputs for remotely starting a regeneration. One input is reserved for an external switch like a push button wired to a control panel as an example. The second input is reserved for an input signal from other devices such as a pressure switch that could signal a regeneration.

RS OFF is the default value. RS ON Immediately would signal a regeneration as soon as the remote button or switch is pushed. RS ON Delay would signal a regeneration to start at the end of the delay period. RS ON Hold would signal a regeneration when the remote button or switch is pushed and held on for the RS Value.

Remote Start
RS OFF
RS ON Immediately
RS ON Delay 10 Min
RS ON Hold
RS Value 2 SEC

AUX RELAY 1 & 2

There are 2 programmable outputs controlled from the start of a regeneration. The default is OFF.

ON Duration Regeneration would open the relay output signal at the start of a regeneration.

Up to 4 steps may be programmed in this mode.

In the On Cycle option you can select which cycles the relay output signal should be on for. All, some, or none of the cycles can be selected.

On for Chemical Pump or Product Water Polish may be selected to designate the relay to control these options.

ADVANCED PROGRAMMING (CONTINUED)



Trip Point Settings

	Trip Delay (SEC)	Trip Flow Rate (GPM)	
		ON	OFF
Unit 1st	30	15	10
Unit 2nd	30	30	20
Unit 3rd	30	45	30
Unit 4th	30	60	40
Unit 5th	30	75	50



Peak Period Block Out

	Start 1	End 1	Start 2	End 2
MON.	06:00	09:00	17:00	19:00
TUES.	06:00	09:00	17:00	19:00
WED.	06:00	09:00	17:00	19:00
THURS.	06:00	09:00	17:00	19:00
FRI.	06:00	09:00	17:00	19:00
SAT.	06:00	09:00	17:00	19:00
SUN.	06:00	09:00	17:00	19:00



Auxiliary Outputs

Remote Start Switch 1	Immediately
Remote Start Switch 1	Hold
AUX Relay 1	Duration Regeneration
AUX Relay 2	Chemical Pump



Salt Efficiency

The following actions will change the system parameters, enter the confirmation needed for set up.

Please Enter Password:

Salt Efficiency Settings

High Efficiency	6 Lbs/CF	2000 Grains
Standard Efficiency	10 Lbs/CF	4000 Grains
High Capacity	15 Lbs/CF	5000 Grains
Minimum Residual	15 %	Minimum Residual/UNIT 3 %



Chemical Pump

CON BY AUX RELAY 1

Volume	100 GAL
Time On	10 SEC



Product Water Polish

CON BY AUX RELAY 2

Min Flow Rate	5 GPM
Time On	20 Sec

Remote Start

RS OFF	OFF
RS ON Immediately	ON
RS ON Delay	10 Min
RS ON Hold	OFF
RS Value	2 SEC

Remote Start

RS OFF	OFF
RS ON Immediately	ON
RS ON Delay	15 Min
RS ON Hold	OFF
RS Value	2 SEC

AUX Relay 1

OFF	OFF
ON Duration Regeneration	ON
ON Cycle	BW, RS
ON For Chemical Pump	ON

Auxiliary Relay 1 Outputs

	ON Time (Min)	Duration (Min)
1	10	5
2	20	5
3	30	5
4	40	5

AUX Relay 1

OFF	OFF
ON Duration Regeneration	ON
ON Cycle	BW, RS
ON For Chemical Pump	ON

AUX Relay 1

<input type="checkbox"/> Backwash
<input checked="" type="checkbox"/> Brine
<input type="checkbox"/> Rinse
<input checked="" type="checkbox"/> Refill
<input checked="" type="checkbox"/> Service

AUX Relay 2

Relay2 OFF	OFF
ON Duration Regeneration	ON
ON Cycle	OFF
ON For Product Water Polish	ON

ADVANCED PROGRAMMING (CONTINUED)

FORMATTING VALVE AND CONTROLLER PCB'S

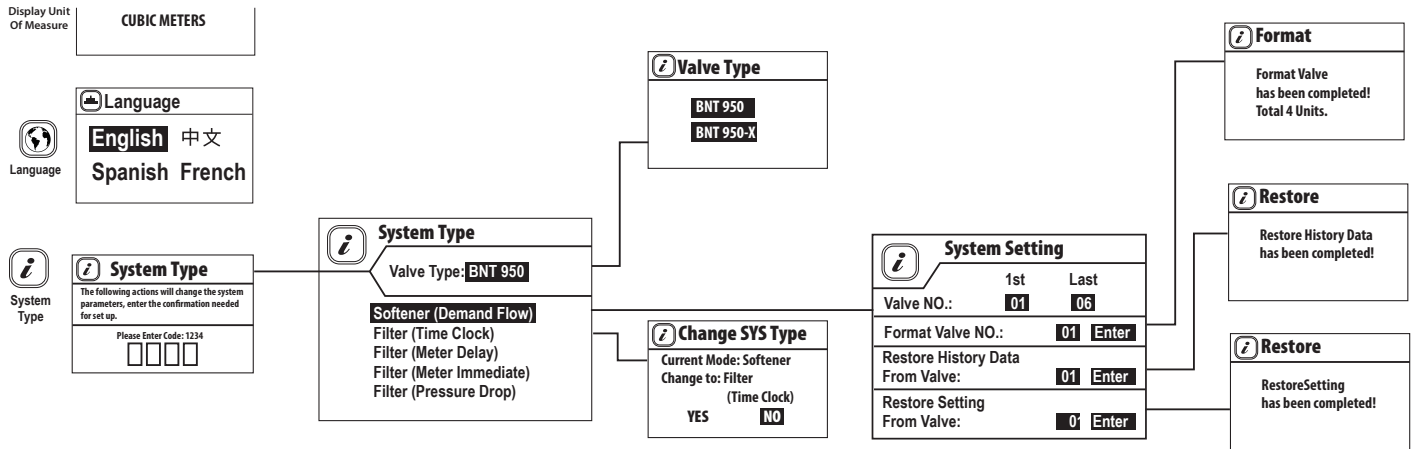

For standard MTS system single valve the default Valve Type is BNT 950. For the 2 piston valve the type is BNT 950-X

When changing from different System Types, a page will displayed that will confirm you want to change the System Type. Select Yes to change the type and No to keep the current settings. A System Setting page will be displayed. Press the MENU button to exit the System Setting page and return to the Main Menu.

If you wish to erase the current valve history (Diagnostic Information), it will be necessary to format the the valve PCB's. If you are changing a valve PCB and want to restore the history and settings, you need to use the "Restore History Data" and "Restore Setting" options, respectively.

The Format Valve function wipes out all the stored settings in the valve PCB. The Restore History Data function will upload the stored settings from the valve PCB to the main PCB. The Restore Settings function will transfer the saved settings from main PCB back to the valve PCB.

RE-FORMAT (ERASE) VALVE PCB SETTINGS & HISTORY DATA

If you wish to reset the history (System Diagnostics) back to zero and start tracking new data the valve PCB's can be re-formatted. You may choose the individual Valve No. or ALL. When you press enter, the history data will be erased and set to zero values.

RESTORE MAIN PCB SETTINGS

If you replace the main PCB, you can restore the current settings and history from the valve PCB's to the Main PCB. Select Restore History Data to restore history data from valve PCB's to new controller PCB. Select Restore Setting to restore valve settings (People, Hardness, Backwash Time, etc.) from Valve PCBs to Main PCB.

MTS WIRING SCHEMATICS

SOFTENER OR FILTER WIRING DIAGRAM

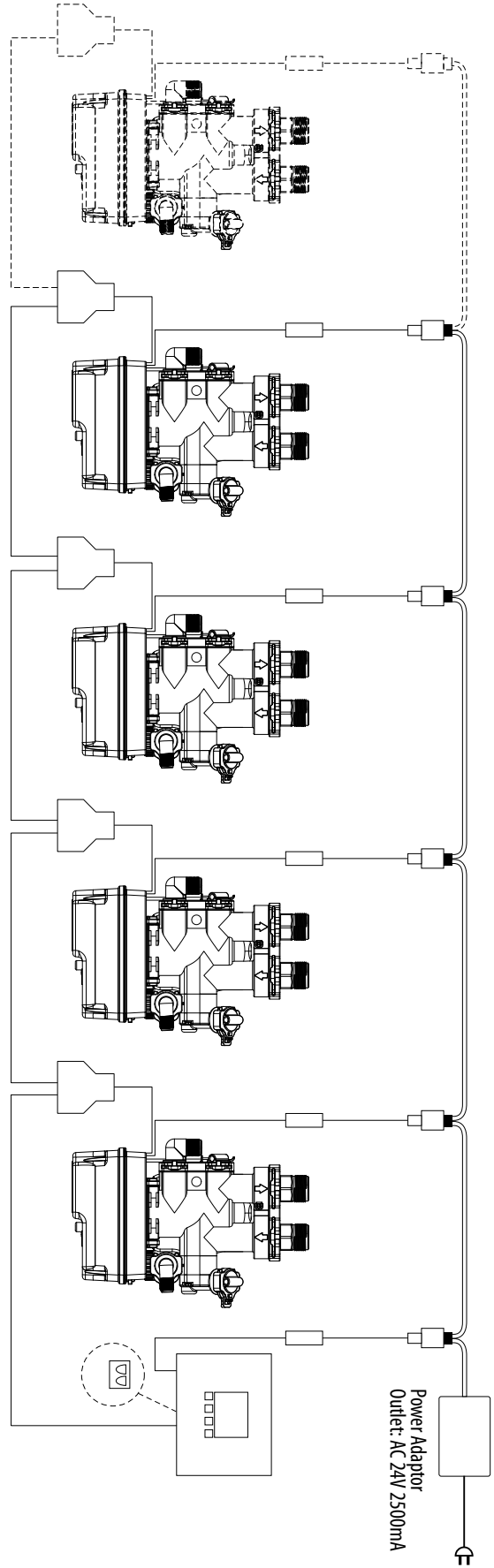
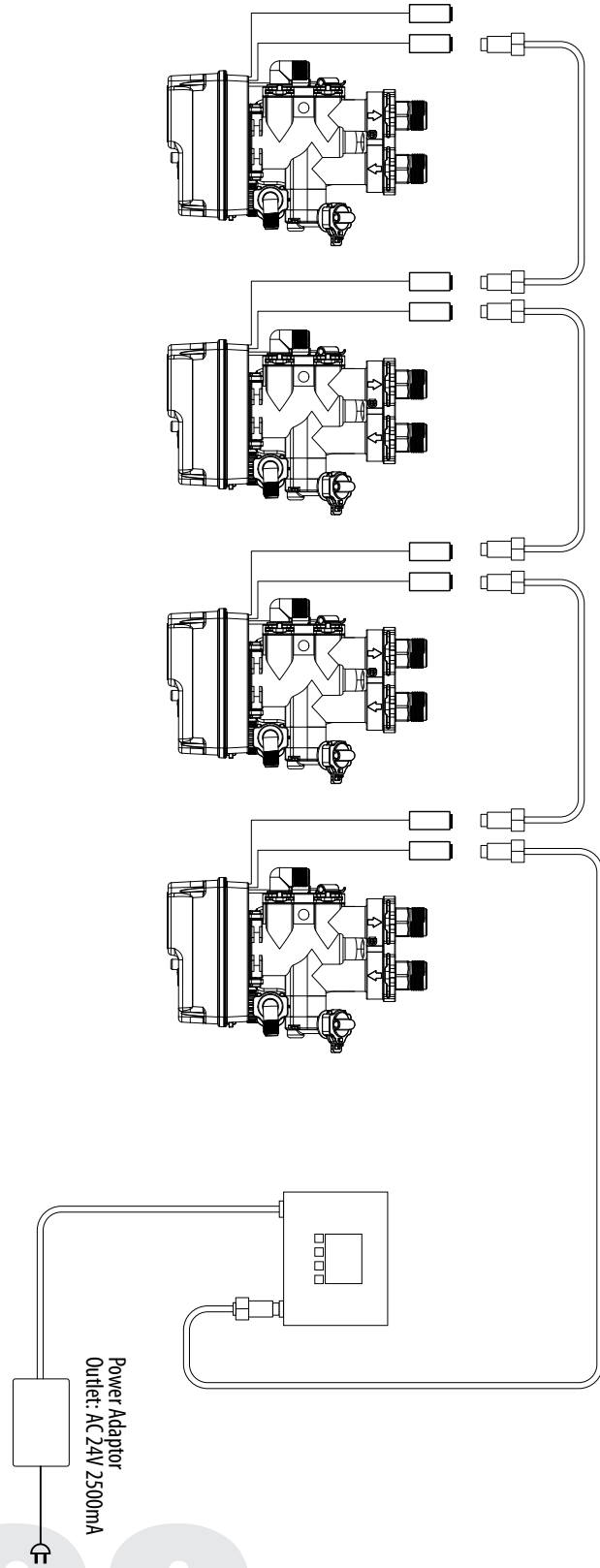

MTS WIRING SCHEMATICS (CONTINUED)

SOFTENER OR FILTER

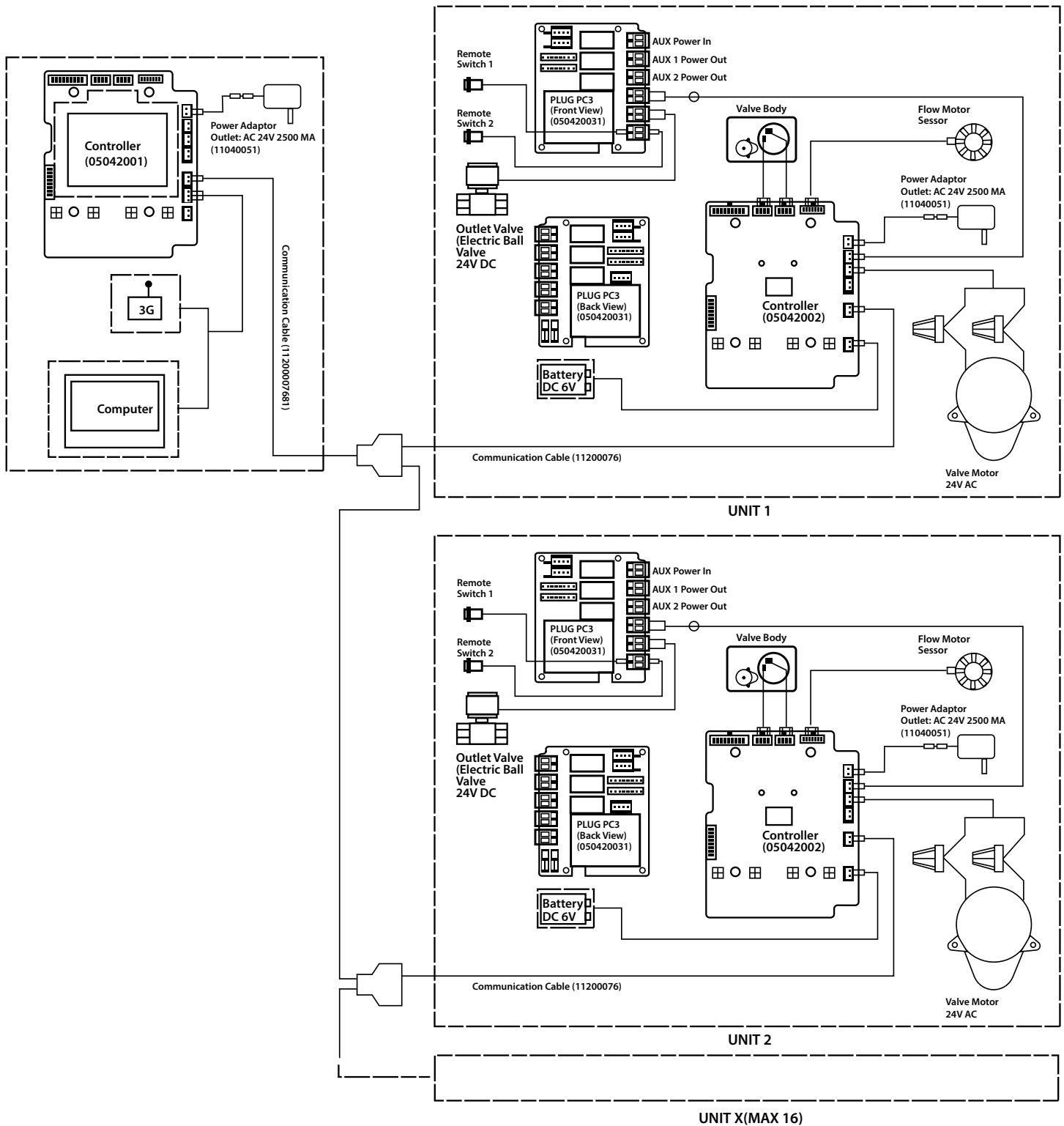

MTS WIRING SCHEMATICS (CONTINUED)

SOFTENER WITH POLISHING RECYCLE OPTION

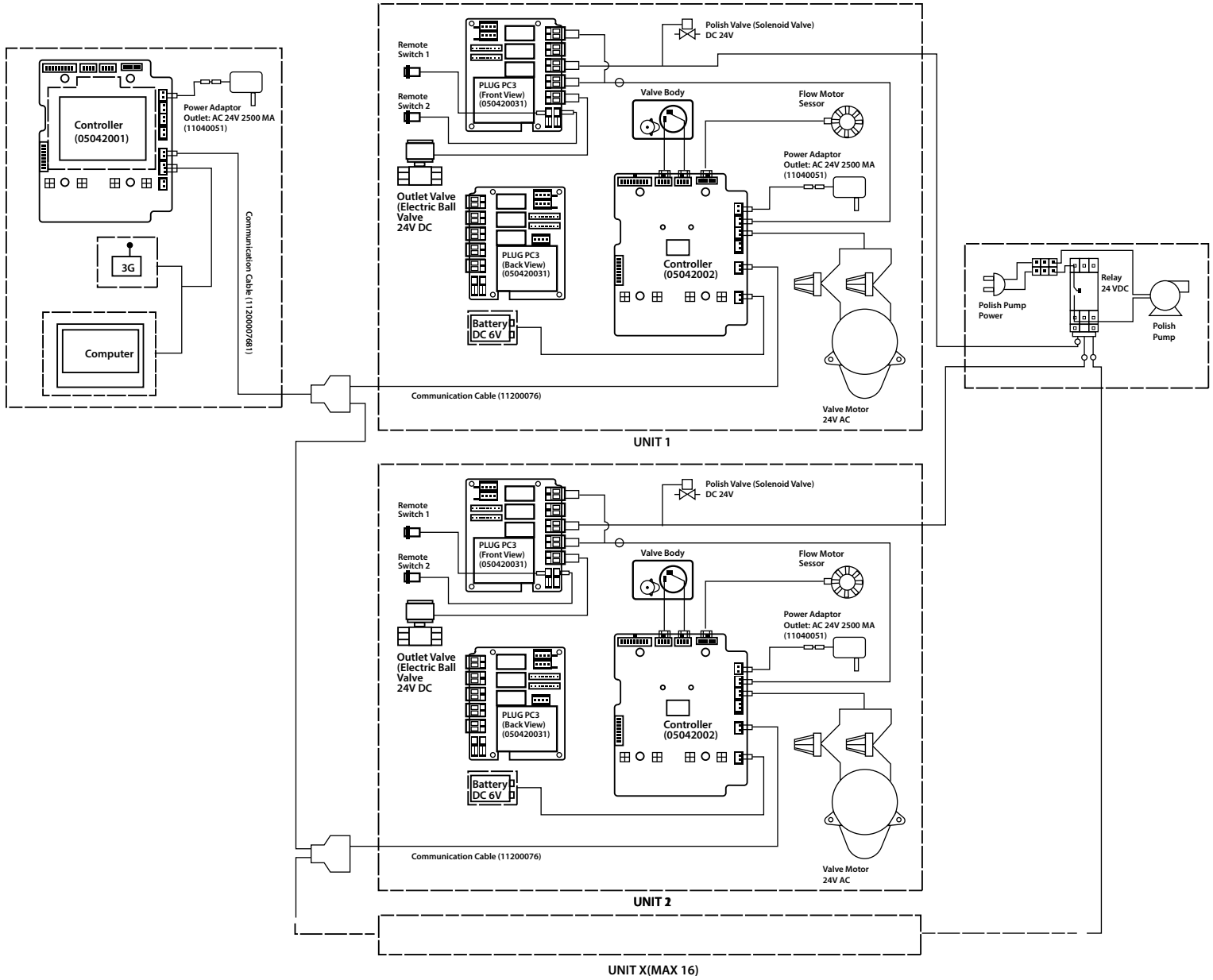

MTS WIRING SCHEMATICS (CONTINUED)

FILTER WITH PRESSURE DIFFERENTIAL SWITCH OPTION

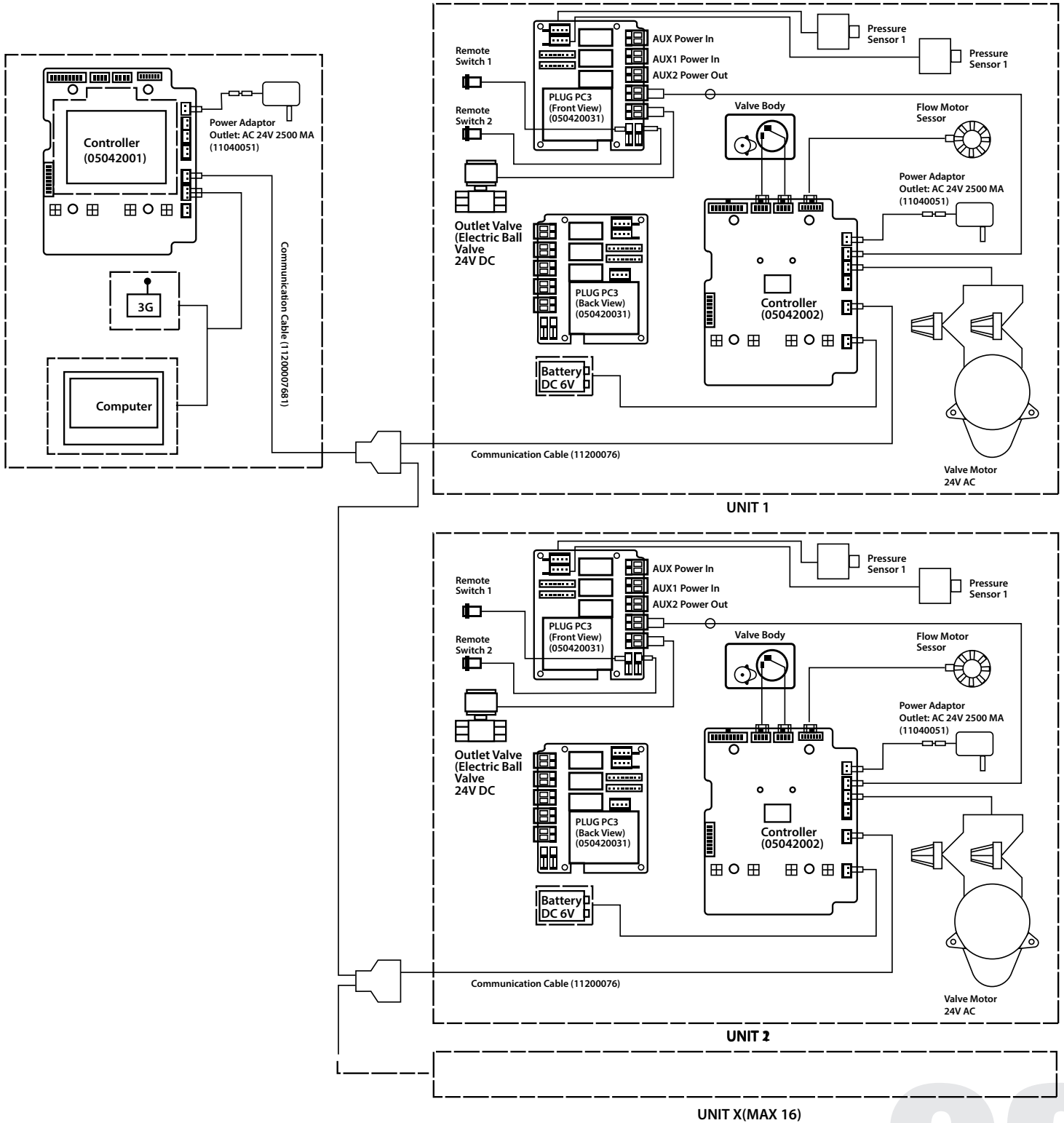

REMOVING POWER HEAD ASSEMBLY

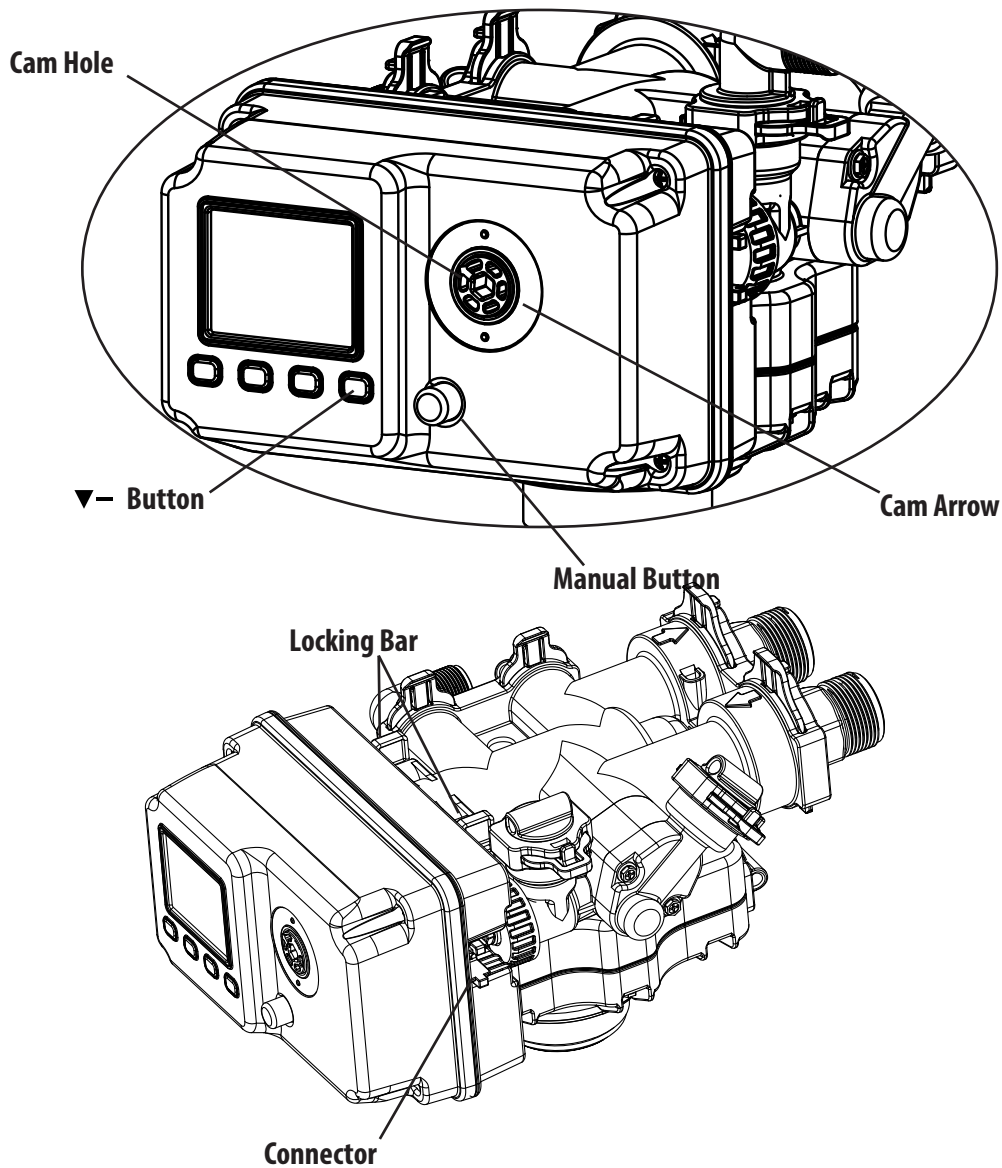

Manually remove the Power Head Assembly:

- Press and hold Manual Button
- With 8 hex key, insert Cam Hole, turn the Cam anti-clockwise to the backwash position
- Remove the Connector
- Remove the Locking Bar
- Pull the Power Head Assembly outwards.

Automatically remove the Power Head Assembly:

- Unlock the screen
- Press and hold Down button, the valve will advance the Cam to the backwash position
- Remove the Connector
- Remove the Locking Bar
- Pull the Power Head Assembly outwards.

REPLACE DRAIN LINE FLOW CONTROL (DLFC)

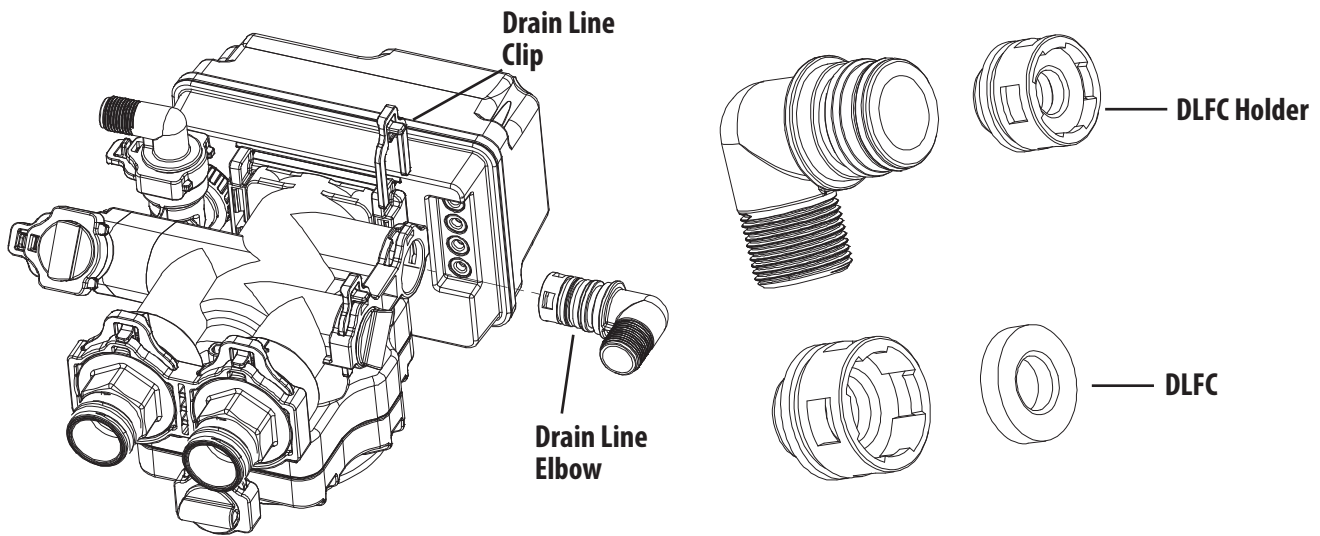

To replace the Drain Line Flow Control (DLFC):

- Remove the Drain Line Clip
- Pull the Drain Line Elbow Assembly outward
- Pull the DLFC Holder outward from the Drain Elbow
- Replace the DLFC

REPLACE BRINE LINE FLOW CONTROL (BLFC)

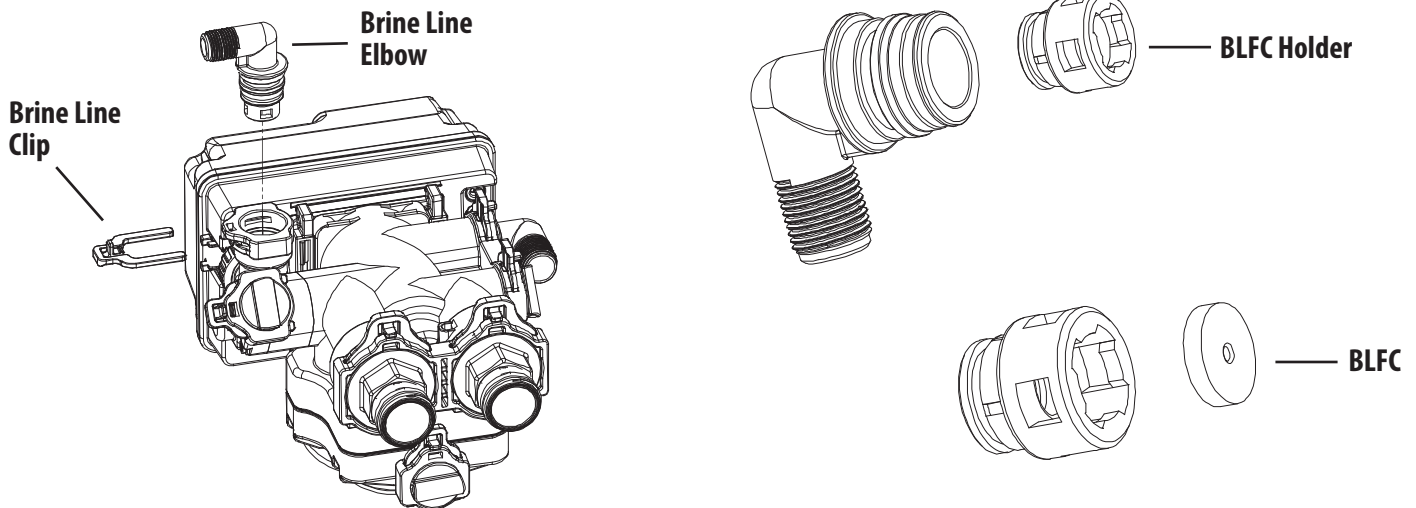

To replace the Brine Line Flow Control (BLFC):

- Remove the Brine Line Clip
- Pull the Brine Line Elbow Assembly outward
- Pull the BLFC Holder outward from the Brine Elbow
- Replace the BLFC

REPLACING OR CLEANING INJECTORS

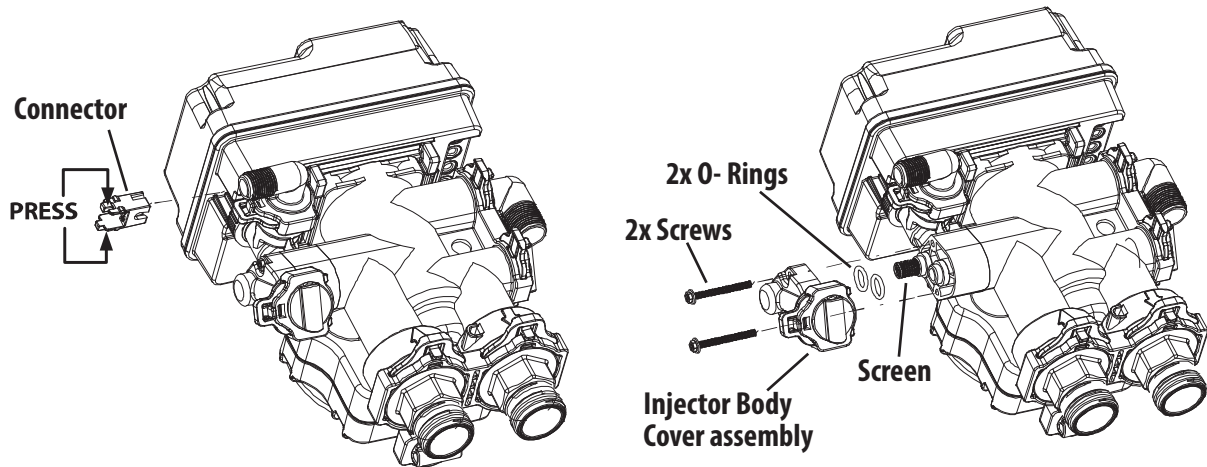

Sediment, salt and silt will restrict or clog the injector. A clean water supply and pure salt will prevent this from happening. The injector assembly is located on the left side of the control valve (viewing valve from rear). This assembly is easy to clean.

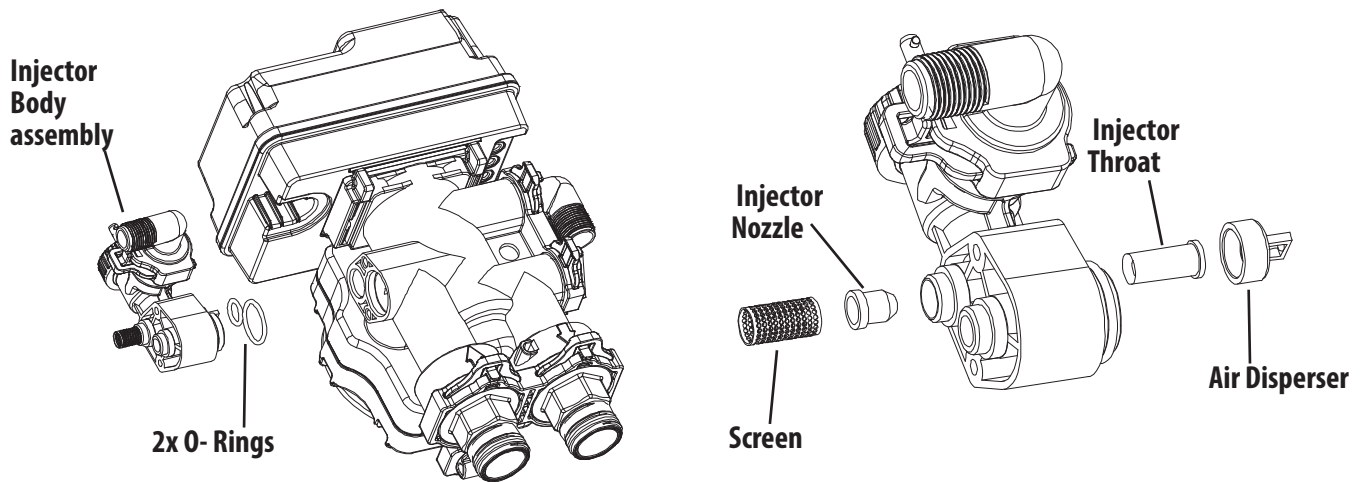

To replace the Injectors:

- Shut off the water supply to your softener and reduce the pressure by opening a cold soft water faucet.
- Remove the Connector
- Remove the 2x Screws
- Slightly pull the Injector Body and Injector Cover assembly outward
- Slightly pull out the Screen
- Replace the Injector Nozzle
- Slightly pull out the Air Dispenser
- Replace the Injector Throat
- Reassemble using the reverse procedure

NOTE: Carefully flush all parts including the screen. Use a mild acid such as vinegar or Pro-Rust Out to clean the small holes in the orifice and throat.

MTS SYSTEM COMPONENTS

10010055 VALVE BNT950 MTS 4" C/W 1.25" BALL VALVE

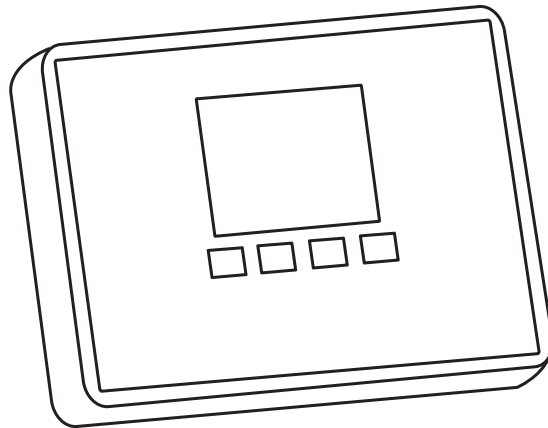
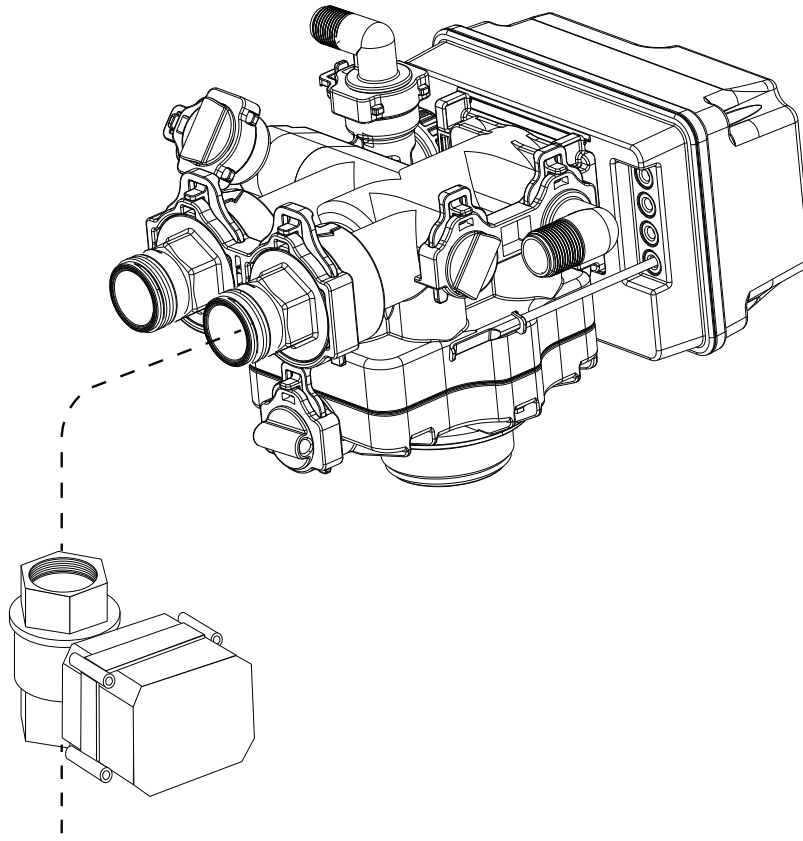

10010056-1: MTS MAIN CONTROLLER

60010183: 95MTS POWER ADAPTOR, TRANSFORMER, 120V INPUT, 24V OUTPUT

60010197-1: MTS COMMUNICATION CABLE 3M

POWER HEAD EXPLODED VIEW

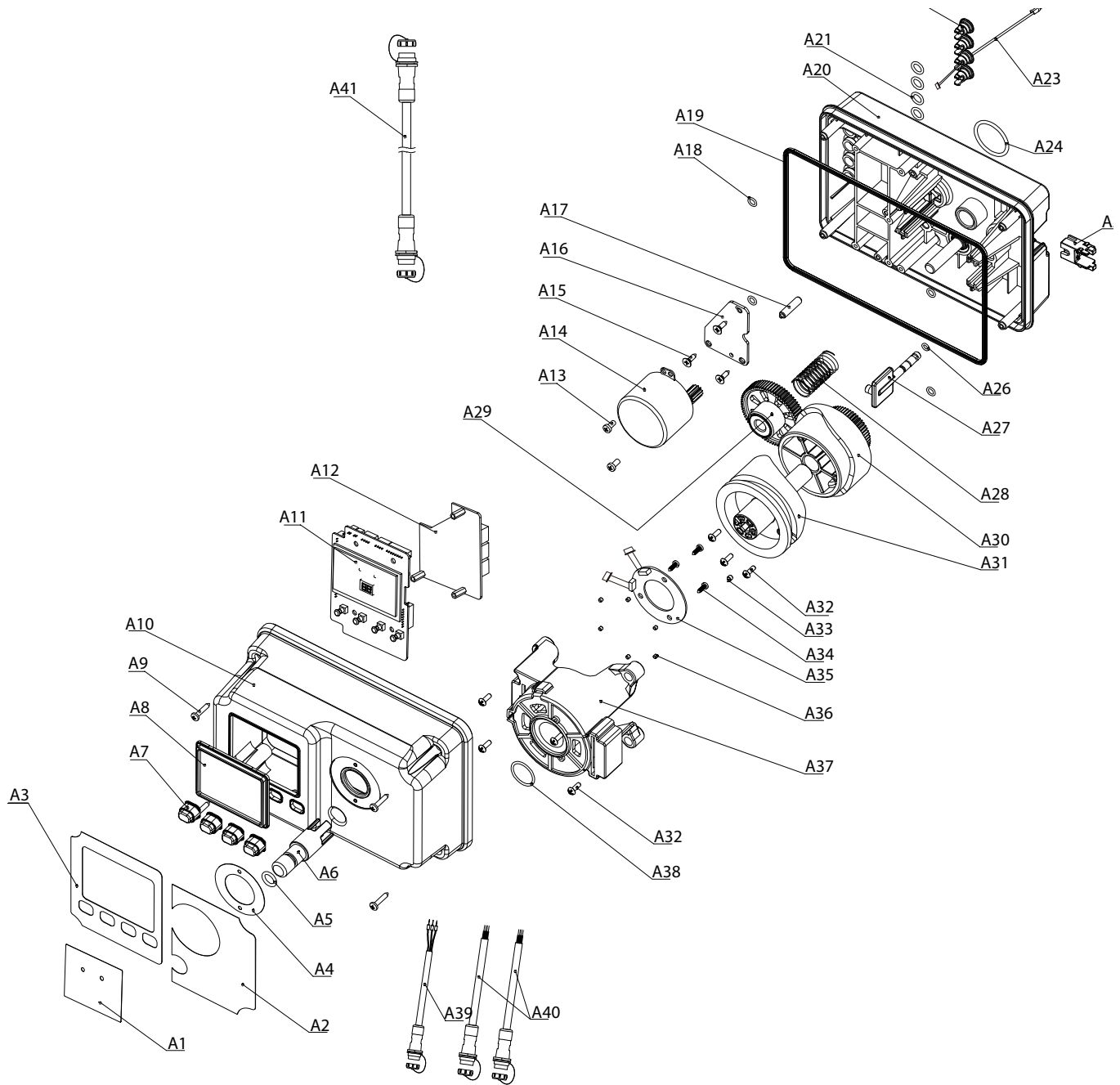

POWER HEAD PARTS NUMBERS

95MTS POWERHEAD			
No.	CAN Part # WG	Description	Qty
A1	60095018	95MTS Window Label	1
A2	50031063	95MTS Right Label	1
A3	50031062	95MTS Left Label	1
A4	60095019	95MTS Working Status Label	1
A5	60010060	O-ring $\phi 10 \times 2.5$	1
A6	60095010	BNT95 Manual Button	1
A7	60010615	Operating Button	4
A8	60095018	Clear Cover on Display	1
A9	05040136	Screw 3.5×20	4
A10	50030062	95/95MTS Cover(Black)	1
A11	60010629	95MTS Main Board	1
A12	60010632	95MTS Subordinate Circuit Board (pre 2017)	1
	60010632N	95MTS Subordinate Circuit Board (post 2017)	
A13	05040137	Screw $M4 \times 8$	2
A14	60021942-1	Motor 24V 7W, with wire	1
A15	60095212	Screw $ST 3.5 \times 13$, pan head	3
A16	05040134	Motor Fixed Plate	1
A17	60095001	Motor Pin	1
A18	60095607	O-ring $\phi 5.5 \times 1.5$	4
A19	60095016	Sealing Gasket on Controller	1
A20	60095000	95/95MTS Housing(Black)	1
A21	60095605	O-ring $\phi 8 \times 2$	4
A22	05040038	95/95MTS Cable Jacket	2
A23	60095611	Meter Cable	1
A24	26010028	O-Ring, 28×2.65	1
A25	60095031	Brine Valve Connector	1
A26	60095606	O-ring $\phi 4 \times 1.5$	1
A27	60095013	Brine Piston Rod	1
A28	60095015	Gear Spring	1
A29	60095002	Gear	1
Cam Assembly	A30	Actuating cam	1
	A31	Inverted cam	1
	A32	Screw $ST 3.5 \times 13$, flat head	7
	A33	Magnet $\phi 4 \times 3$	1
A34	60095005	Screw 2.9×9.5	3
A35	60095009	Signal Sensor Board	1
A36	05010047	Friction Block	6
A37	60095007	Mounting Plate	1
A38	60010562	O-ring $\phi 23 \times 3$	1
A39	60095020	Ball Valve Connection(3 pins female)	1
A40	60095012	Communication Cable (4 pins female)	2
A41	60010197-1	Communication Cable(4 pins male, 2 ends)	1

PARTS NOT SHOWN	
Part #	Description
10010056-1	MTS Main Controller
60095955-1	MTS powerhead
60010183	95MTS Power Adaptor, Transformer, 120V Input, 24V Output
12100064	Wires(Red&black, red plug)
12100064B	Wires(White&green, black plug)
60024290	Electric Ball Valve, 1.25" NPT, MTS
60024292	Electric Ball Valve, 1" NPT, MTS
60024293	Electric Ball Valve, 1.5" NPT, MTS

VALVE BODY EXPLODED VIEW

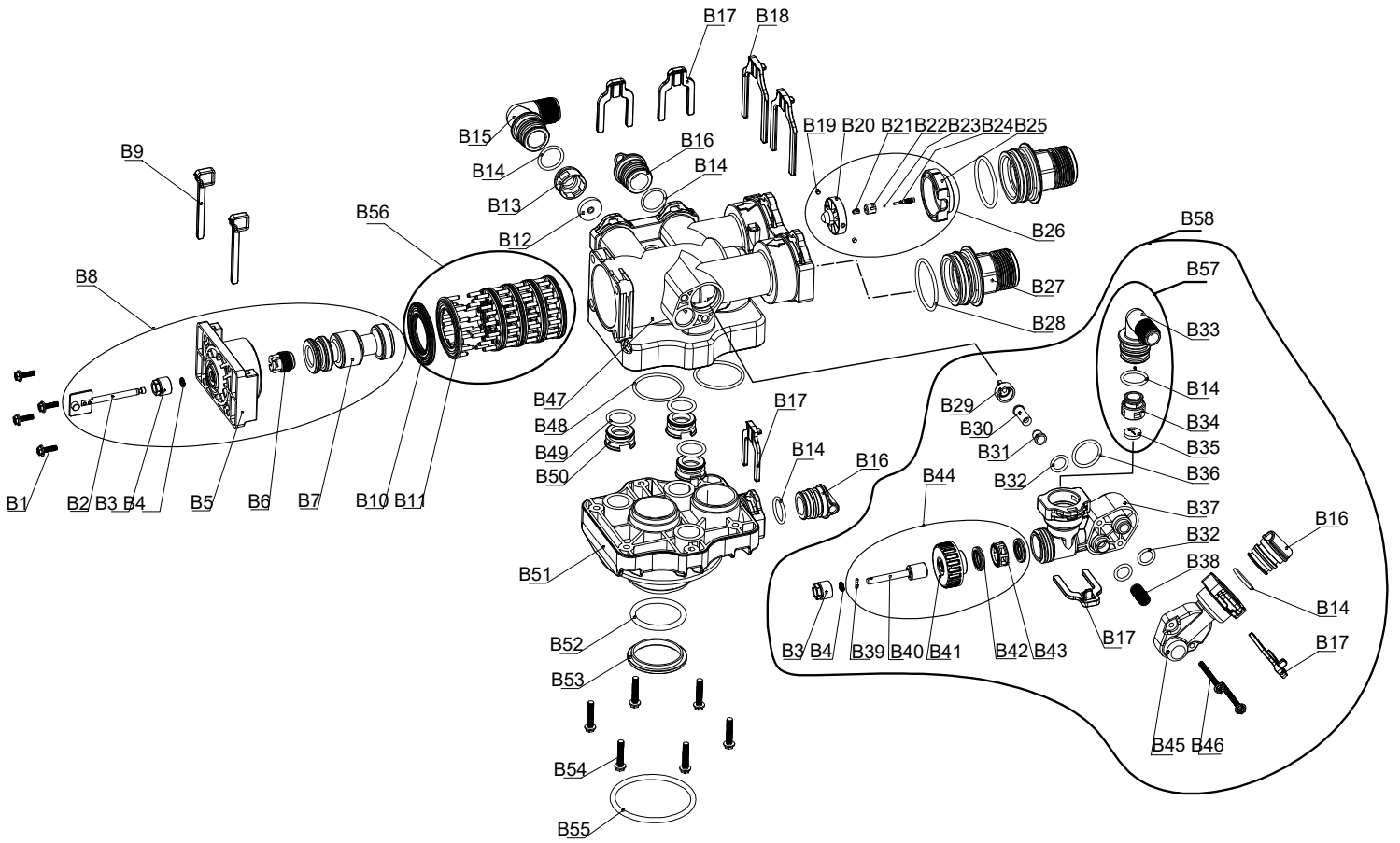

VALVE BODY PARTS NUMBERS

95STS/MTS VALVE BODY		
No.	Part # WG	Description
B1	05056088	Screw M5×16
B2	60095650	95 Piston Rod
B3	60095661	Quad Ring Holder
B4	60095735	Quad Ring (5.81×1.83)
B5	5040004M	End Plug Retainer
B6	60095663	Piston Rod Holder
B7	60095732	95 Piston
B8	60010218	95 Piston Assy
B9	60095024	Housing Locking Bar
B10	60010260	95 Spacer Seal
B11	60095022	95 Spacer
B12	60010140	DLFC(5gpm)
B13	60095694	DLFC Holder
B14	60010211	O-ring φ25×3
B15	60010254	Drain Line Elbow NPT1"
B16	60010212	95 Plug
B17	60010227	95 Small Clip
B18	60010226	95 Large Clip
B26 - Meter Assembly	B19	Magnet φ4×3
	B20	95 Meter
	B21	Meter Pin Top Bush
	B22	Meter Pin Bush
	B23	Meter Ball
	B24	Meter Pin
	B25	Impeller Holder
B27	60010214	Valve Connector, NPT 1.25"
B28	60010216	O-ring φ48.7×3.55
B29	60095048	Air Disperser
B30	60010155	Injector Throat
B31	60010149	Injector Nozzle
B32	60095610	O-ring φ14×3
B33	60010232	Brine Line Elbow BSP 1/2"
B34	12054	BLFC Holder
B35	60010161	BLFC(0.95gpm)
B36	60010561	O-ring φ27×3
B37	60095038	95 Injector Body
B38	60095042	Brine Valve Screen
B44 - Brine Valve Assembly - Piston, Seal & Spacer	B39	Brine Valve Rod Pin
	B40	Brine Valve Piston
	B41	Brine Valve Seal Cover
	B42	Brine Valve Seal
	B43	Brine Valve Spacer
B45	Included in 60010219	95 Injector Body Cover

VALVE BODY PARTS NUMBERS (CONTINUED)

95STS/MTS VALVE BODY		
B46	60095041	Bolt M5×50
B47	60095211	95 Valve Body
B48	60095608	O-ring φ47×3
B49	26010158	O-ring φ23.39×3.53
B50	05040123	Auxiliary Hole Plug
B51	60010243	95 Valve Body Base(4")
B52	05042005	O-ring φ46.99×5.33
B53	05040091M	Sealing Collar
B54	60095034	Screw M6×30
B55	60010228	O-ring φ108×5.3
B56	60010219	Seal & Spacer kit, 95
B57	60010224	BRINE ELBOW KIT 95
B58	02171063	Injector,B.ValveAssy 95 valve c/w Body

PARTS NOT SHOWN		
	Part #	Description
DLFC Options	60010144	#2, 9.5 gpm, Flat
	60010145	#3, 12.5 gpm, Flat
	60010146	#4, 16.5 gpm, Flat
	60010142	#7S, 7.0 gpm, Flat
Connector Options	60010213	Valve Connector, NPT 1"
	60010215	Valve Connector, NPT 1.5"
Injector Throat Options	60010156	5S, Orange
	60095047	1, Grey
	60010157	3, Red
	60010158	4, White
	60010155	4S, Black
Injector Nozzle Options	60010154	4S, Black
	60095043	1, Grey
	60010151	3, Red
	60010152	4, White
BLFC Option	60010162	#7, 1.5 gpm
Options to connect tubing to brine line	60010217	CONNECTOR,STRAIGHT,1/2" BSPx3/8" TUBE
	60010230	STRAIGHT CONNECTOR 1/2" BSP X 1/2" TUBE A7-FAB7

TROUBLE SHOOTING

Issue	Possible Cause	Possible Solution
A. Unit fails to initiate a regeneration cycle.	1. No power supply.	Check electrical service, fuse, etc.
	2. Defective circuit board.	Replace faulty parts.
	3. Power failure.	Reset time of day.
	4. Defective meter.	Replace turbine meter.
B. Water is hard.	1. By-pass valve open.	Close by-pass valve.
	2. Out of salt or salt level below water level.	Add salt to tank.
	3. Plugged injector / screen.	Clean parts.
	4. Flow of water blocked to brine tank.	Check brine tank refill rate.
	5. Hard water in hot water tank.	Repeat flushing of hot water tank required.
	6. Leak between valve and central tube.	Check if central tube is cracked or o-ring is damaged. Replace faulty parts.
	7. Internal valve leak.	Replace valve seals, spacer, and piston assembly.
	8. Reserve capacity setting too low.	Increase reserve capacity.
	9. Not enough capacity.	Increase salt dosage.
C. Salt use is high.	1. Refill time is too high.	Check refill time setting.
	2. Defective flow control.	Replace.
D. Low water pressure.	1. Iron or scale build up in line feeding unit.	Clean pipes.
	2. Iron build up inside valve or tank.	Clean control and add resin cleaner to clean bed. Increase regeneration frequency.
	3. Inlet of control plugged due to foreign material.	Remove piston and clean control valve.
	4. Deteriorated resin. (Maybe caused from high chlorine or chloramines.)	Re-bed unit. Consider adding carbon pre-treatment.
E. Resin in drain line.	1. Air in water system.	Check well system for proper air eliminator control.
	2. Incorrect drain line flow control (DLFC) button.	Check for proper flow rate.
F. Too much water in brine tank.	1. Plugged injector or screen.	Clean parts.
	2. Valve not regenerating.	Replace circuit board, motor, or control.
	3. Foreign material in brine valve.	Clean parts.
	4. Unit not drawing brine.	Check for vacuum leak in brine line connections.
G. Unit fails to draw brine.	1. Drain line flow control is plugged.	Clean parts.
	2. Injector or screen is plugged.	Clean parts.
	3. Inlet pressure too low.	Increase pressure to 25 PSI.
	4. Internal valve leak.	Replace seals, spacers, and piston assembly.
	5. Safety valve closed.	Check for leak in brine line connections. Replace safety float assembly.
	6. Vacuum leak in brine line.	Check for leak in brine line connections. Tighten all connections.
	7. Drain line has kink in it or is blocked.	Check drain line.
H. Valve continuously cycles.	1. Defective position sensor PCB.	Replace faulty parts.
I. Flow to drain continuously.	1. Valve settings incorrect.	Check valve settings.
	2. Foreign material in control valve.	Clean control.
	3. Internal leak.	Replace seals, spacers, and piston assembly.
	4. Piston is stuck in position. Motor may have failed or gears have jammed or disengaged.	Check for power to motor. Check for loose wire. Check for jammed gears or gears disengaged. Replace faulty parts.
J. Valve makes beeping sound.	1. The piston has not advanced to the next cycle position properly.	Check for power to motor. Check for loose wire. Check for jammed gears or gears disengaged.

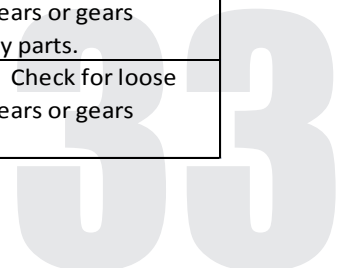

MAINTENANCE LOGS

System Model:

The service below is to be performed on each tank

Annual Maintenance Log

: Installation Date

: Tank #

Date	Regeneration cycles times are correct	Valve advances through each cycle correctly	Injector(s) and screen(s) cleaned and free from damage	Flow control(s) cleaned and free from damage	Piston clean and free from damage	Confirm ball valve(s) fuction (if applicable)	Brine float cleaned and free of damage	Brine Tank cleaned	Flow meter is clean and free from damage

For warranty claims, Canature WaterGroup reserves the right to ask for this maintenance sheet. Failure to provide this completed form for the time period requested will void your warranty.

MAINTENANCE LOGS (CONTINUED)

System Model:

Monthly Maintenance log

Installation Date:

Date	Brine float moves freely (Y/N)	Leaks to drain during service? (Y/N)	Height of resin from floor (each tank)	Treated Water Hardness (each tank)	Brine tank overflow connection(s) installed to drain and clean	Total system treated water

For warranty claims, Canature WaterGroup reserves the right to ask for this maintenance sheet. Failure to provide this completed form for the time period requested will void your warranty.

MAINTENANCE LOGS (CONTINUED)

System Model:

Weekly Maintenance Log

Installation date:

Date	Number of regenerations completed				Height of brine from ground			
	Tank 1	Tank 2	Tank 3	Tank 4	Tank 1	Tank 2	Tank 3	Tank 4

MAINTENANCE LOGS (CONTINUED)

System Model:

Daily Maintenance Log

:Installation Date

Date	Brine tank full of salt and brine	Raw water hardness	Treated hardness (system)	Alarms?

Date	Brine tank full of salt and brine	Raw water hardness	Treated hardness (system)	Alarms?

For warranty claims, Canature WaterGroup reserves the right to ask for this maintenance sheet. Failure to provide this completed form for the time period requested will void your warranty.

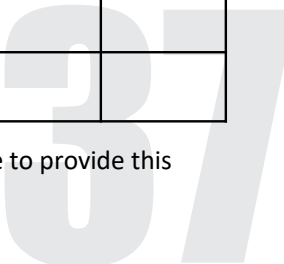

MAINTENANCE LOGS (CONTINUED)

System Model:

Please print one of these for EACH brine tank

Brine tank salt addition sheet.

:Tank #

Date	Number of regeneration(s) for corresponding softener tank	Weight of Salt added

Date	Number of regeneration(s) for corresponding softener tank	Weight of Salt added

For warranty claims, Canature WaterGroup reserves the right to ask for this maintenance sheet. Failure to provide this completed form for the time period requested will void your warranty.

WARRANTY

COMMERCIAL SOFTENER & FILTER UNIT WARRANTY

NOTICE: THIS MANUAL CONTAINS A LIMITED WARRANTY. BY INSTALLING AND/OR USING THIS PRODUCT, YOU WAIVE CERTAIN LEGAL RIGHTS INCLUDING THE RIGHT TO SUE OR CLAIM COMPENSATION IN THE EVENT OF PROPERTY DAMAGE, INJURY AND/OR DEATH. PLEASE READ THE DOCUMENT CAREFULLY AS CONTAINS IMPORTANT INFORMATION ABOUT YOUR WARRANTY AND EXCLUSIONS.

Products manufactured and assembled by Canature WaterGroup™ are warranted to do the work for which they are intended where properly installed, operated and maintained. Canature WaterGroup™ warrants each new commercial water softener to be free from defects in materials and workmanship subject to the qualifications or exclusions below.

Commercial Systems are defined by pressure tank size and / or the amount of resin or filter media contained in the tank. Commercial systems use 14" [355mm] diameter tanks and can contain above 3.0 cubic feet [84.95 L] of resin or filter media.

Products manufactured by Canature WaterGroup™ are warranted to be free from defects in materials and workmanship where properly installed, operated and maintained. The length of the product warranties vary as per below.

WARRANTY TABLE FOR ASSEMBLED UNITS	
Fiberglass tanks 14"-63" in diameter or larger	5 Years
Control Valves & Electronics	5 Years
Diaphragm Valves, Meters & Electric Ball Valves	1 Year
Brine Tanks And Internal Assemblies	1 Year
Media	Limited to warranty provided by original manufacturer
Vinylester / Hot Water Application Max Temp 150F	1 Year
Steel Tanks (epoxy lined)	1 Year
Other Components Manufactured by Canature Watergroup	1 Year
Other Components Not Manufactured by Canature Watergroup	Limited to warranty provided by original manufacturer

Canature WaterGroup™ will replace any part (except for Wear and Tear Items – Media, Piston, Seals and Brine Valve) which fails within the time period specified in the chart above from date of manufacture, as indicated by the serial number, provided the failure is due to a defect in material or workmanship. The only exception shall be when proof of purchase or installation is provided and then the warranty period shall be from the date thereof.

Warranty on Mineral Tanks and Brine Tanks:

Canature WaterGroup™ will provide a replacement mineral tank or brine tank to any original equipment purchaser in possession of a tank that fails within the time outline in the chart above, provided that the system is at all times operated in accordance with specifications and not subject to freezing or vacuum.

Exclusions: Damage to any part of this water softener or filter as a result of misuse, misapplication, neglect, alteration, accident, installation or operation contrary to our printed instructions, damage to ion exchange resin and seals caused by chlorine / chloramines in the water supply, damage to internal pistons and seals caused by wear and tear from iron, manganese, sediment and or silt, or damage caused by any force of nature is not covered in this warranty.

On fiberglass tanks 24" diameter or larger, due to slight expansion and contraction of the tanks, flexible connectors must have been properly installed between the tank openings and rigid piping. Also, a vacuum breaker(s) must have been properly installed to protect the tank from vacuum under all conditions. Failure to install flex connectors and/or vacuum breaker(s), or improper installation the tank warranty will be void.

In addition, if the fiberglass tank has a tripod base, it must have been properly and securely attached to the floor. If not done or improperly installed, the tank warranty will be void.

At our sole discretion, we will repair or replace defective parts if our warranty department determines it to be defective under the terms of this warranty. Canature WaterGroup™ assumes no responsibility for consequential damage, labor or expense incurred as a result of a defect or failure. Media and Resin coverage is limited to the warranty provided by the original manufacturer.

As a manufacturer, we do not know the characteristics of your water supply. The quality of water supplies may vary seasonably or over a period of time. Your water usage may vary as well. Water characteristics can also change if the appliance is moved to a new location. For these reasons, we assume no liability for the determination of the proper equipment necessary to meet your requirements, and we do not authorize others to assume such obligation for us. Further, we assume no liability and extend no warranties, express or implied, for the use of this product with a non-potable water source or a water source which does not meet the conditions for use as described in the Owners Guide.

CANATURE WATERGROUP'S™ OBLIGATIONS UNDER THIS WARRANTY ARE LIMITED TO THE REPAIR OR REPLACEMENT OF THE FAILED PARTS OF THE WATER TREATMENT SYSTEM AND WE ASSUME NO LIABILITY WHATSOEVER FOR DIRECT, INDIRECT, INCIDENTAL, CONSEQUENTIAL, SPECIAL, GENERAL OR OTHER DAMAGES.

Return of Goods: An authorization number must be obtained before returning any merchandise. NOTE: All material returned to Canature Watergroup must be returned freight prepaid. Upon inspection, if our warranty department determines the goods to be defective under the terms of this warranty, the warranty shall be limited to the defective parts to be repaired, replaced, or credited at Canature WaterGroup's discretion. You pay only freight to return defective parts to our factory and local dealer charges, including but not limited to labor charges, travel and transportation expenses, and handling fees.

Some State & Provincial jurisdictions do not allow limitations on how long an implied warranty lasts, so the above limitation may not apply to you. Similarly, some State & Provincial jurisdictions do not allow exclusion of incidental or consequential damages, so the above limitations or exclusions may not apply to you. This warranty gives you specific legal rights, and you may also have other rights, which vary from jurisdiction to jurisdiction. Consult your authorized Dealer for warranty and service information

Toll Free: 1-877-759-5159
www.canaturewgroup.com